

Building Dryer WDH-35B

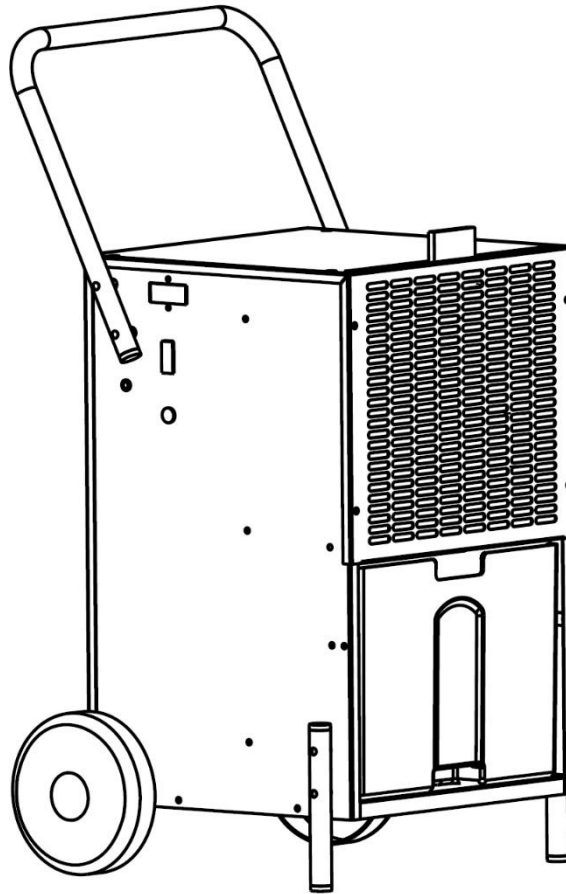

Dear Customer,

You have chosen a high-quality product. To ensure that you get a lot of enjoyment from this product, here are a few more tips:

In case of any problems:

We hope that the unit meets your expectations! If, despite the greatest possible care, there should ever be cause for complaint, please contact us briefly, as we are very concerned about your satisfaction and would like to clear up any misunderstanding.

Mounting the transport handle:

To reduce the volume, the transport handle of a new unit was mounted the wrong way round.

The following accessories are included for the transport handle assembly:

1 x transport handle
4 x long hexagon head screws

- First loosen and remove the four hexagonal screws together with the washers with which the handle is attached to the unit the wrong way round.
- Now position the handle in the right direction so that it points diagonally backwards and the four fastening holes of the handle are above the fastening holes on the unit casing. (See the cover picture of the operating instructions).
- Then screw in the four hexagonal screws to secure the handle to the unit. Make sure that the washers are between the hexagon head screw and the handle. We recommend using a spanner or a suitable ratchet for fastening.
- Now your handle should be stable and firmly attached and nothing should stand in the way of safe transport.

Note: We also recommend checking whether the fastening screws of the feet are tightened or whether they have loosened during transport. If this is the case, you can also tighten the screws with a spanner or a suitable ratchet.

After transport or assembly:

As the unit works with cooling liquid, we ask you to let it stand upright for at least 1 hour before using it for the first time or after mounting the castors and the transport handle, so that the cooling liquid can settle properly in the unit again.

During first operation / hose connection:

If you want to use a hose connection for draining the condensate, make sure that the hose connection is properly seated and that the condensate (water) can always drain off unhindered! If this is not observed, the water condensed by the building dryer (up to 35 litres per day) can cause damage to the room!

Room humidity and dehumidification performance:

If you want to check the room humidity and the associated dehumidification performance with your own humidity meter (hygrometer), please avoid attaching this humidity meter to a wall, as this will falsify the true humidity content of the room air. See also the explanations under Troubleshooting !!!

Important safety instructions:

- Supervise the building dryer when children are near the unit !
- Watch out for electricity - never walk into or insert objects into the appliance !
- Do not place any objects on the construction dryer !
- Do not block the exhaust and intake louvres of the unit and please ensure sufficient space/clearance at and around the fan !
- Make sure that there is sufficient air supply to the unit, otherwise it can lead to a reduction in performance and, in the worst case, to overheating and/or fire ! Please always keep a distance of approx. 20 cm to the wall to avoid possible overheating of the unit ! Do not use in airtight rooms !
- Only qualified personnel or electricians are allowed to open the unit or carry out repairs !
- Make sure that no moisture gets into or onto the unit !
- Use only the recommended voltage (220V-240V / 50Hz) to operate the appliance !
- Make sure that the power cable is unfolded (untied) before connecting it to the socket !
- Make sure that the plug is cleanly and properly connected to the socket before using the appliance !
- Do not use multiple sockets to operate the building dryer !
- Make sure that highly flammable substances (e.g. gases/oils etc.) are never in the vicinity of the unit !
- Do not use any insect, oil or paint spray etc. near the building dryer. This may cause damage to the unit or even fire !
- If you are not going to use the unit for a long time, switch it off and disconnect the mains plug !
- Do not disconnect the mains plug by pulling on the power cable !
- Please keep the unit away from heat sources and avoid direct sunlight !
- Always hold and transport the unit in its proper position ! Never place the unit on its side or even upside down !
- Make sure that the unit is properly earthed via the earthed plug supplied !

Please switch off the unit immediately and disconnect it from the mains/power supply if anything seems to be wrong !!! In this case, please contact a specialist and do not attempt to repair the unit yourself !!!

Examples: Fan does not run during operation, fuse has blown, there is a funny smell or the compressor rattles loudly.

Important operating and safety instructions regarding the refrigerant R290 in this unit:

- Read these instructions carefully and observe them strictly !
- The unit operates with the refrigerant R290. This refrigerant is highly flammable and explosive if the safety instructions are not observed!
- The unit should not be stored or operated in a room with burning/heating appliances or open fire !
- Please note that the refrigerant is odourless and therefore a leak cannot be detected immediately by an emerging odour !
- Make sure that the outlet of the exhaust air is always ensured and not obstructed by other objects !
- Ensure a minimum distance of at least 50 cm from open flames and heating elements !
- Set-up, operation and storage of the unit should take place in a room with a minimum size of 10 m² !
- When cleaning, proceed strictly according to the manufacturer's instructions and do not use any additional heat sources to possibly accelerate the defrosting process of the appliance !

This unit has parts that must not be replaced or repaired !

The refrigerant cannot be renewed or replaced !

Do not carry out any independent repairs or modifications to your unit !

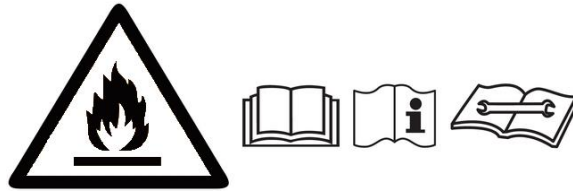

Description of the unit parts:

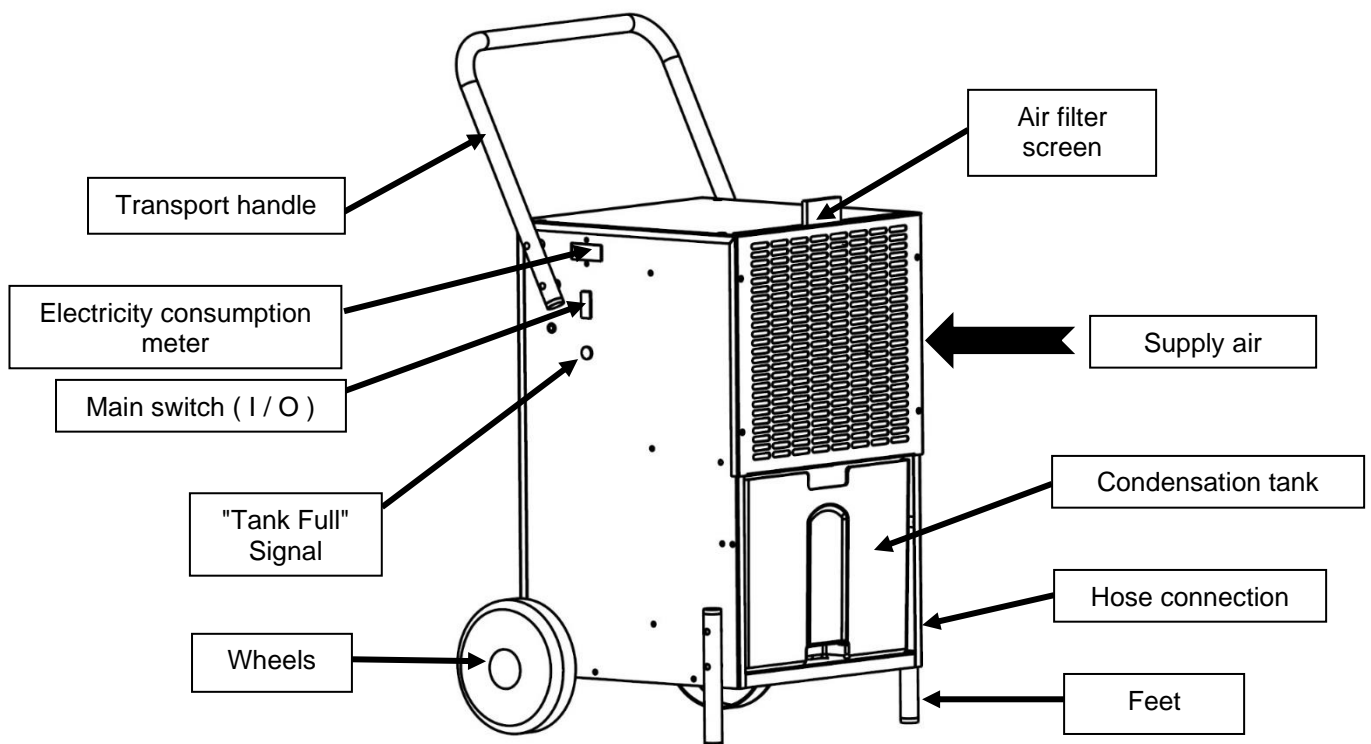

Instructions for use:

1. Commissioning

Insert the mains plug properly into the socket.

Switch on the unit with the main switch (I / O).

The unit is programmed so that the building dryer runs in continuous operation (continuous dehumidification). This means that you do not have to make any further settings.

Switch the unit off again with the main switch (I / O) if dehumidification is no longer required.

Operating instructions

To protect the compressor, the unit should always run for at least 3 minutes or be switched off before you press the main switch (I / O) again!!!

In case of cold ambient temperatures or icing in the unit, a sensor automatically controls a defrosting process. Meanwhile, the defrost mode automatically controls the air circulation and compressor operation !

2. Connecting a hose

- 2.1. The connection point for the drain hose is on the right-hand side of the condensation tank (see diagram below). First remove the black sealing plug there.
- 2.2. It is best to use a ½ inch plastic hose and pass it through the hole provided on the side and then put the hose over the plastic tap provided.
- 2.3. Make sure that it fits properly. For safety, we recommend fixing the hose with a clamp/clip !
- 2.4. Make sure that the hose does not kink and must always have a slight slope !

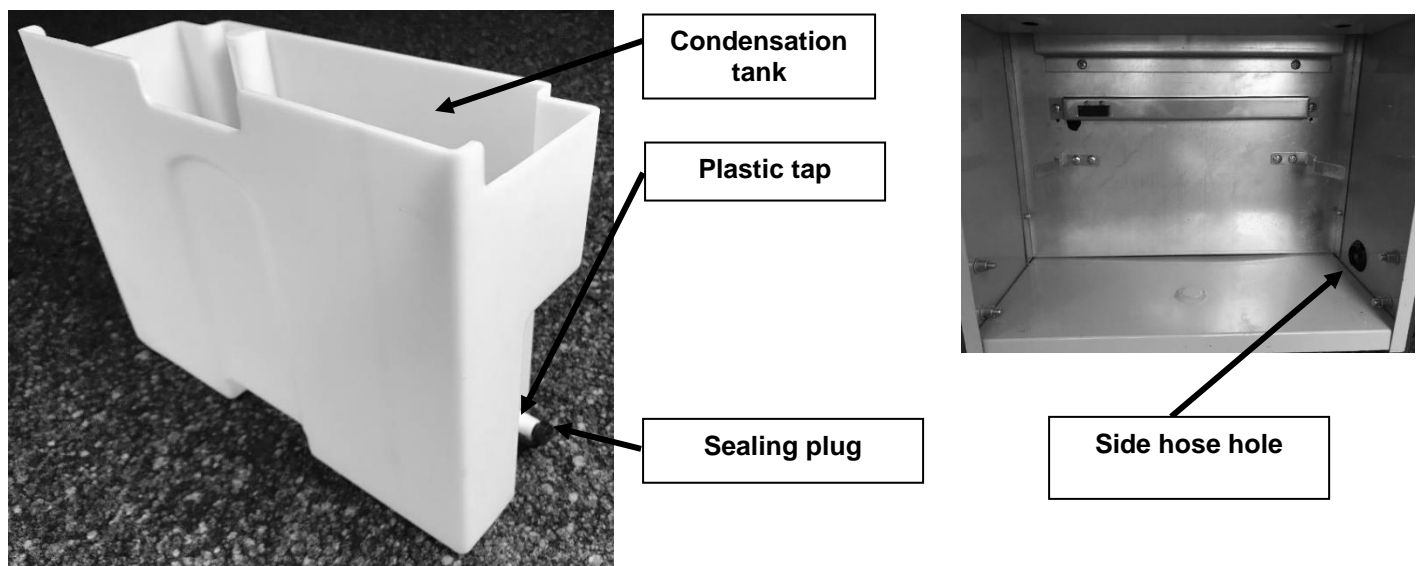

3. Cleaning

3.1. Cleaning the housing

- Please disconnect the mains plug before cleaning the construction dryer.
- Only use mild cleaning agents to clean your construction dryer.
- NEVER spray your building dryer (e.g. with water or similar).

3.2. Cleaning the air filter screen

The air filter screen at the front of the air intake filters lint, hair and coarse construction dust. Furthermore, the air filter ensures that less dust is deposited on the cooling fins, thus ensuring higher efficiency. Too much dust and dirt in the filter sieve or on the cooling fins reduces the dehumidification performance and can lead to a loss of efficiency in the In the worst case, this can even cause damage to your construction dryer, so the following applies in the case of coarse soiling or in rooms with a lot of construction dust: clean the air filter screen and also the inner evaporator unit* (*only possible after opening the casing) regularly !

- Clean the filter whenever it can be assumed that the air intake is reduced by the dirty air filter screen or that dirt and dust has been deposited on the cooling fins. (This can sometimes even be the case daily on dusty construction sites.)
- Switch off the unit and disconnect the mains plug !
- Now remove the air filter screen by pulling it upwards by the tab.
- Wash the dirty sieve well under lukewarm water or vacuum it out thoroughly with a Hoover.
- Allow the air filter screen to dry and then put it back into its holder from above.

4. Other notes

Do not expose the compressor to temperatures above 45°C. Please do not do this even if the unit is not switched on/connected. This could damage the compressor !

The exhaust air of the building dryer is approx. 2°C - 3°C warmer than the supply air (room temperature). In smaller and well-insulated rooms this can lead to greatly increased room temperatures, this process is quite normal.

For an effective and economical dehumidification operation, please close all doors and windows in the operating room of the building dryer, if possible !

Technical data

Model name:	WDH-35B
Voltage:	220-240V ~ 50Hz
Maximum power consumption:	560 W (2.6 A)
Dehumidification capacity (optimal):	42 ltr./day (35°C / 90% r.h.)
Dehumidification capacity (standard):	37 ltr./day (30°C / 80% r.h.)
Air circulation:	Approx. 230 m³/h
Compressor:	Rotary compressor
Dimension (H/W/D):	780 x 420 x 420 mm
Weight:	22 kg
Waterproofness:	IPx0
Cooling pressure (max.):	2.5 MPa
Vapour pressure (max.):	1.0 MPa
Coolant:	R290 (135 g)
Range of use:	5°C - 35°C

For the technical data, deviations are reserved !!!

Troubleshooting

The unit is icing up.

In cold temperatures or long periods of continuous operation, the unit may freeze up despite the defrost sensor. In this case, we recommend that you manually defrost the unit by switching it off and warming the room slightly.

The unit does not dehumidify enough.

Please remember that the primary aim is not to gain as much condensation water as possible, but to dry and/or keep dry the room air or ceilings, walls and inventory !

Furthermore, bear in mind that the building dryer can only remove moisture from the air and only indirectly from materials (screed/plaster). Depending on the condition of the ceilings, walls and fixtures, it can take several weeks before they release the stored moisture back into the air! For this reason, we also recommend that if you use your own humidity meter (hygrometer), you place it as freely as possible and somewhat away from walls and ceilings, because otherwise the determined humidity value of the room air will be falsified!!!

As with all building dryers, the dehumidification performance is decisively influenced by the following factors:

A) Humidity content of the room air and B) Heat/temperature in the room.

For safety's sake, here is an approximate dehumidification table for DURABLE OPERATION:

35 degrees and <u>90% r.h.</u> = approx. 40 litres (optimum or maximum capacity).	
30 degrees and <u>80% r.h.</u> = approx. 35 litres	and at <u>60% r.h.</u> = approx. 18 litres
20 degrees and <u>80% r.h.</u> = approx. 18 litres	and at <u>60% r.h.</u> = approx. 11 litres
15 degrees and <u>80% r.h.</u> = approx. 14 litres	and at <u>60% r.h.</u> = approx. 8 litres
10 degrees and <u>80% r.h.</u> = approx. 9 litres	and at <u>60% r.h.</u> = approx. 6 litres

All figures are approximate per day (fluctuation tolerance) when measured directly at the unit inlet and of course these values only apply if the temperature and moisture content remain constant!

Other

Warranty statement:

Notwithstanding the statutory warranty claims, the manufacturer grants a warranty in accordance with the laws of your country, but at least 1 year (in Germany 2 years for private individuals). The warranty begins on the date of sale of the appliance to the end user.

The warranty only covers defects that are due to material or manufacturing faults.
are.

Warranty repairs may only be carried out by an authorised customer service. To

To make your warranty claim, please enclose the original sales receipt (with date of sale).

Excluded from the guarantee are:

- Normal wear
- Improper applications, such as overloading the appliance or non-approved accessories.
- Damage due to external influences, use of force or foreign objects
- Damage caused by non-observance of the operating instructions, e.g. connection to an incorrect mains voltage or non-observance of the assembly instructions.
- Completely or partially dismantled units

Conformity:

The building dryer has been tested and itself and/or parts thereof have been manufactured under the following (safety) standards:

Of course with CE conformity.

CE (LVD) Conformity tested according to:

EN 60335-2-40:2003+A11:2004+A12:2005+A1:2006+A2:2009+A13:2012
EN 60335-1:2012+A11:2014+A13:2017+A1:2019+A14:2019+A2:2019+A15:2021
EN 62233:2008

EMC conformity tested according to:

EN IEC 55014-1:2021
EN IEC 55014-2:2021
EN IEC 61000-3-2:2019+A1:2021
EN 61000-3-3:2013+A1:2019+A2:2021

Correct disposal of this product:



Within the EU, this symbol indicates that this product should not be disposed of with household waste. Old appliances contain valuable recyclable materials that should be recycled. In addition, the environment or human health should not be harmed by uncontrolled waste disposal. Therefore, please dispose of old appliances via suitable collection systems or send the appliance for disposal to the place where you bought it. They will then recycle the appliance.



I wish you much pleasure with this appliance.

Your Aktobis AG

Keep these instructions for use in a safe place !